

**13 Bolt Pan
13954X**

1989-94
Subaru Justy

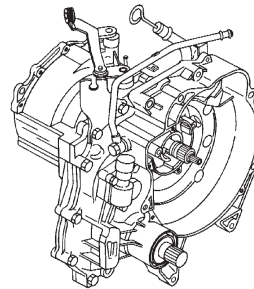

ECVT Case

REBUILDER KITS

DESCRIPTION	QTY.	YEAR	DELUXE KIT	MASTER O/H KIT	LESS STEELS KIT	OVERHAUL KIT	GASKET & SEAL KIT
Overhaul Kit	1	89-94				K20900	

ILL.	DESCRIPTION	QTY.	YEAR	PART NO.	REFERENCE NO.
------	-------------	------	------	----------	---------------

MISCELLANEOUS GASKETS & SEALS/PAN GASKETS

N.I.	Gasket - Oil Pan - Cork & Neoprene	1	89-94	13954X	31397-KA031
N.I.	Gasket - Extension Housing - 4WD	1	89-94	13953	31335-KA030

FILTERS/FILTER KITS

N.I.	Filter Kit - Oil Strainer	1	89-94	FK20800	N.L.
N.I.	Filter - Oil Strainer	1	89-94	20800	31728-KA031

METAL CLAD SEALS

N.I.	Clutch Housing - 28 x 42 x 7mm	1	89-94	20200	80672-8070
N.I.	Differential - Right - 27 x 45x 9mm.....	1	89-94	20205	80672-7070
N.I.	Differential - Left - 27 x 45 x 9mm.....	1	89-94	20206	80672-7080
N.I.	Manual Shift Arm - 16 x 26 x 5mm.....	1	89-94	20203	80671-6020
N.I.	Main Drive Gear - 10 x 22 x 6mm.....	1	89-94	20201	80671-0030
N.I.	Speedometer Shaft - 12 x 17.5x 8mm	1	89-94	20202	80671-2090
N.I.	Extension Housing - 4WD - 30 x 45 x 9mm	1	89-94	20204	80673-0110

HARD PARTS - NEW

N.I.	Drive Chain	1	89-94	20973	32435-KA000
N.I.	Forward & Reverse Syncro Rings:				
	- 1989-90	2	89-90	20915	32627-KA010
	- 1990-91	2	90-91	20915A	32627-KA030
	- 1991-94	2	91-94	20915B	32627-KA080

ELECTRICAL PRODUCTS

N.I.	Solenoid Assembly - Pressure.....	1	89-94	5A-186	31752-KA001
N.I.	Solenoid Transfer	1	89-94	5A-186B	31940-KA000
N.I.	Wiring Harness - 2WD	1	89-94	35A-102	24031-KA000
N.I.	Wiring Harness - 4WD	1	89-94	35A-103	24031-KA010

GENERAL MOTORS, CHRYLSEY & FORD REAR WHEEL BEARING REPAIR KITS

APPLICATIONS

B350

'C' Axle Size 1.399 - 10
Bolt
Light Duty

The rollers of the old bearing wear a groove into the axle. The B350 or B351 will roll on the unworn part of the axle. They are prelubricated with high temperature lithium grease, and have two seals completely sealing the bearing from the differential fluid. Enables use of worn axle shafts.

B351

'P' Axle Size 1.618 Bolt
Heavy Duty

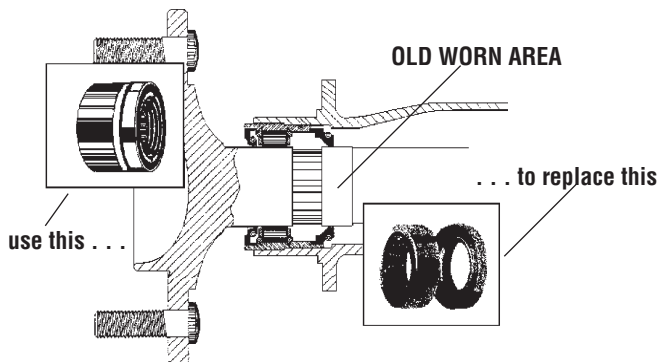

MAKE/MODEL/AXLE TYPE	YEAR	PART#
GM CARS & TRUCKS		
Buick Centurion, Electra, Estate Wagon, LeSabre, & Wildcat 'C' Axle	70-88	B350
'P' Axle	73-88	B351
Cadillac DeVille, Fleetwood Brougham, Seville 'C' Axle	75-88	B350
Cadillac Commercial, Fleetwood Sedan, & Limo 'P' Axle	77-88	B351
Chevrolet Camaro, Chevelle, Chevy II, Malibu, Nova, Vega, Van, Blazer, Suburban, Chevrolet & GMC Trucks 1/2 Ton & S10, S15 'C' Axle	64-88	B350
'P' Axle	64-88	B351
OLDSMOBILE		
Delta 88, Ninety Eight, Delmont 88, Custom Cruiser, Cutlass, F-85, Vista Cruiser, Omega & Starfire 'C' Axle	68-88	B350
'P' Axle	73-88	B351
PONTIAC		
Catalina, Bonneville, Grandville, Astre, Sunbird, Firebird, Grand Prix, LeMans, Tempest, Ventura II & Phoenix 'C' Axle	70-88	B350
'P' Axle	71-88	B351
CHRYLSEY, DODGE, PLYMOUTH		
All models - full size and compact. 8-1/4" Ring Gear, 10" Brake	75-88	B350
8-1/4" Ring Gear, 11" Brake	71-88	B351
9-1/4" Ring Gear	71-88	B351
Trucks - 1/2 Ton 8-3/8" & 9-1/4" Ring Gear	72-88	B351
FORD PASSENGER		
Granada, Fairmount, LTD II, Maverick, Mustang, Thunderbird, Lincoln & Mercury Marquis, Monarch, Montego, Zephyr, Capri II, Comet & Cougar 7-1/2" & 8-1/2" Ring Gear - Integral Rear End	67-88	B350
Trucks, Ranger & Bronco II 7-1/2" Ring Gear	82-88	B350
1/2 Ton & 3/4 Ton Sterling Axle	83-88	B351

CHRYLSEY FRONT WHEEL DRIVE INNER AXLE BEARINGS

	79-89	Omni, Horizon - all w/1.6 & 1.7 engine	40mm Bore	B254	4271389
	79-84	Aries, Reliant	76mm O.D.	B254	5212541
	82-84	LeBaron, New Yorker, 'E' class	33mm Wide	B254	-
	84-Up	LeBaron, GT, S, 'K' bodies, 'E' class, T-115	42mm Bore	B250	4397498
			76mm O.D. 40mm Wide		